

Low Power Ambient Light and Proximity Sensor with Internal IR-LED and Digital Output

ISL29044

The ISL29044 is an integrated ambient and infrared light-to-digital converter with a built-in IR LED and I²C Interface (SMBus Compatible). This device uses two independent ADCs for concurrently measuring ambient light and proximity in parallel. The flexible interrupt scheme is designed for minimal microcontroller utilization.

For ambient light sensor (ALS) data conversions, an ADC converts photodiode current (with a light sensitivity range up to 2000 Lux) in 100ms per sample. The ADC rejects 50Hz/60Hz flicker noise caused by artificial light sources.

For proximity sensor (Prox) data conversions, the built-in driver turns on an internal infrared LED and the proximity sensor ADC converts the reflected IR intensity to digital. This ADC rejects ambient IR noise (such as sunlight) and has a 547µs conversion time.

The ISL29044 provides low power operation of ALS and proximity sensing with a typical 133µA normal operation current (108µA for sensors and internal circuitry, ~25µA for LED) with 220mA current pulses for a net 100µs, repeating every 800ms (or under).

The ISL29044 uses both a hardware pin and software bits to indicate an interrupt event has occurred. An ALS interrupt is defined as a measurement that is outside a set window. A proximity interrupt is defined as a measurement over a threshold limit. The user may also require that both ALS/Prox interrupts occur at once, up to 16 times in a row before activating the interrupt pin.

The ISL29044 is designed to operate from 2.25V to 3.63V over the -40°C to +85°C ambient temperature range. It is packaged in a clear, lead-free 8 Ld ODFN package.

Features

- Internal LED + Sensor = Complete Solution
- Works under all light sources including sunlight
- Dual ADCs measure ALS/Prox concurrently
- <1.0µA Supply current when powered down
- Temperature compensated
- Pb-Free (RoHS compliant)

Intelligent and Flexible Interrupts

- Independent ALS/Prox interrupt thresholds
- Adjustable interrupt persistency
 - 1/4/8/16 consecutive triggers required before interrupt

Applications

- Display and keypad dimming adjustment and proximity sensing for:
 - Mobile devices: Smart phone, PDA, GPS
 - Computing devices: Laptop PC, Netbook, Tablet PC
 - Consumer devices: LCD-TV, digital picture frame, digital camera
 - Industrial and medical light and proximity sensing

Related Literature

- See [AN1436](#), "Proximity Sensors"

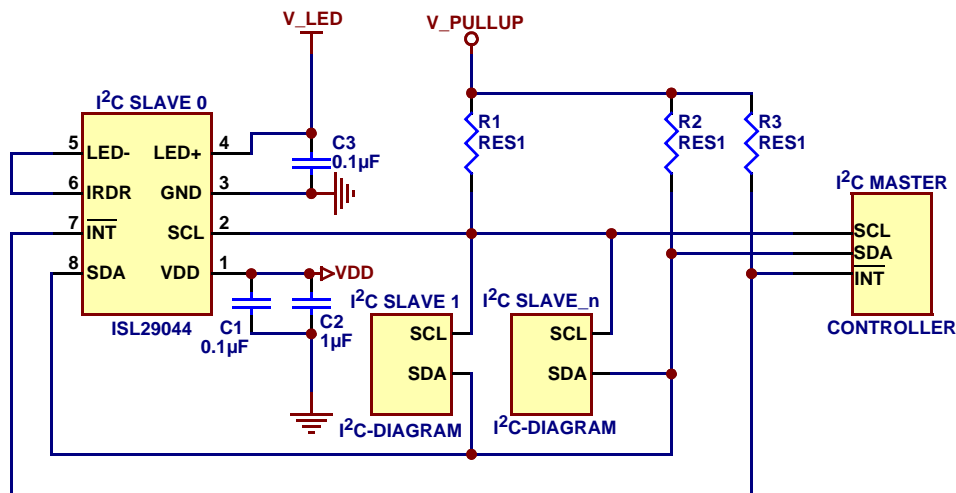

FIGURE 1. TYPICAL APPLICATION

For additional products, see www.intersil.com/product_tree

Intersil products are manufactured, assembled and tested utilizing ISO9000 quality systems as noted in the quality certifications found at www.intersil.com/design/quality

Intersil products are sold by description only. Intersil Corporation reserves the right to make changes in circuit design, software and/or specifications at any time without notice. Accordingly, the reader is cautioned to verify that data sheets are current before placing orders. Information furnished by Intersil is believed to be accurate and reliable. However, no responsibility is assumed by Intersil or its subsidiaries for its use; nor for any infringements of patents or other rights of third parties which may result from its use. No license is granted by implication or otherwise under any patent or patent rights of Intersil or its subsidiaries.

For information regarding Intersil Corporation and its products, see www.intersil.com